

## 3" & 4" Engine Driven Self-Priming Trash Pumps



Model  
3S9XHR

- **Cast Aluminum with Internal Cast Iron Wearparts for Durability**
- **Silicon Carbide/Viton® Mechanical Seal**
- **EPDM/EPR O-Rings Standard with Optional Viton®**
- **3" or 4" Removable Male NPT Suction and Discharge Ports**
- **Discharge Rotates in 90° Increments**
- **Engine Options: Honda, B & S Vanguard Gasoline or Hatz Diesel Engines**
- **Maximum Solids Handling up to 2"**
- **Maximum Flow up to 530 GPM**
- **Maximum Head up to 112 Ft.**
- **Self-Priming to 26 Ft.**
- **Wheel Kit Optional**

IPT Portable High Volume, Self-priming Centrifugal Trash pumps include easy cleanout with replaceable cast iron impeller and volute that resist abrasion/wear. All pumps feature aluminum housing, cast iron wearparts, built-in check valve, suction strainer and heavy duty steel roll frame. Heavy duty cast iron flanges with male NPT threads that rotates in 90° increments. Easy access fill plug on discharge port.

Performance of Engine Driven Self-Priming Trash Pumps

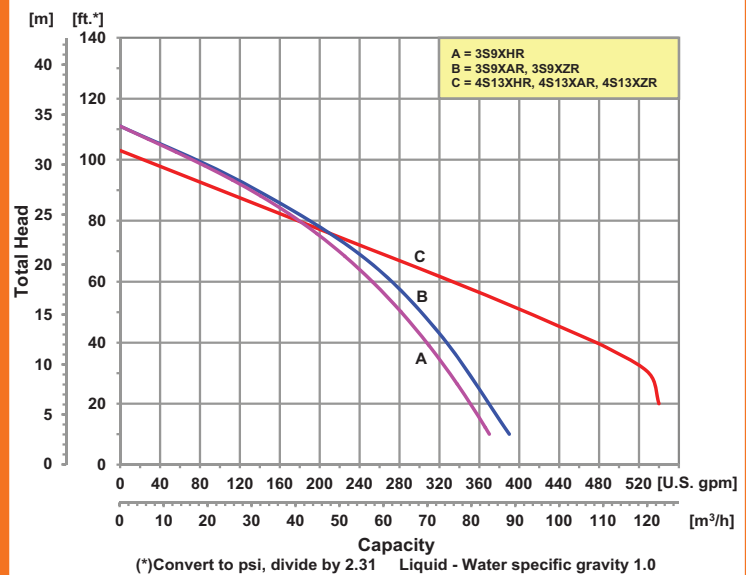

## 3" Trash Pumps

Model	HP Class♦	Curve	Port	Driver	Seal	Run Time (Hours)	Tank Size (Gal./Ltr.)	Ship Wt. (Lbs.)
3S9XHR	8 HP	A	3" NPT	Honda GX270▲	Viton®/ SIC-SIC	2.5	1.40/5.2	145
3S9XAR	8 HP	B	3" NPT	B & S Vanguard▲	Viton®/ SIC-SIC	1.5	0.95/3.6	145
3S9XZR	8 HP	B	3" NPT	Hatz 1B40**▲	Viton®/ SIC-SIC	1.9	1.32/5.0	240

**Construction: Cast Aluminum with Cast Iron Components**

♦ HP Class represents market category and is not intended to define actual horsepower.

**Maximum Solids Handling Capacity:**  
1½" Diameter

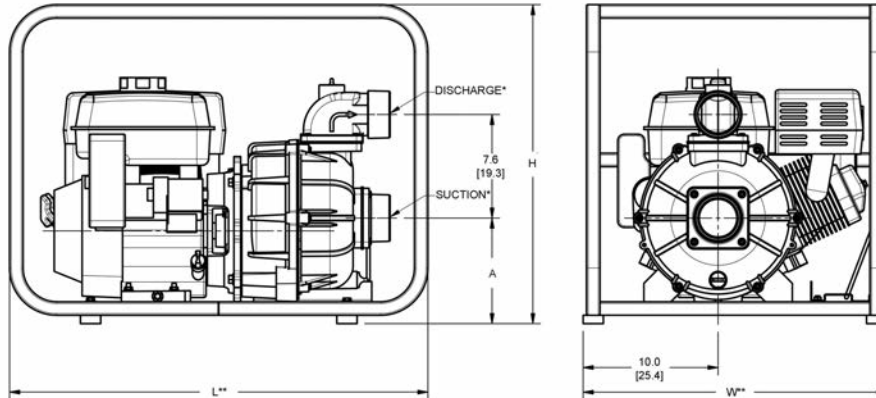

## 4" Trash Pumps

Model	HP Class♦	Curve	Port	Driver	Seal	Run Time (Hours)	Tank Size (Gal./Ltr.)	Ship Wt. (Lbs.)
4S13XZR	13 HP	C	4" NPT	Hatz 1B50**▲	Viton®/ SIC-SIC	1.8	1.32/5.0	240
4S13XAR	13 HP	C	4" NPT	B & S Vanguard V-Twin**	Viton®/ SIC-SIC	1.8	2.25/8.5	195
4S13XHR	13 HP	C	4" NPT	Honda GX390**▲	Viton®/ SIC-SIC	2.5	1.60/6.1	200

**Construction: Cast Aluminum with Cast Iron Components**

♦ HP Class represents market category and is not intended to define actual horsepower.

\*\* 12V DC Electric Start (Battery Not Included—use BCI Group: U1 or U2)

▲ Oil Alert Included

**Maximum Solids Handling Capacity:**  
2" Diameter

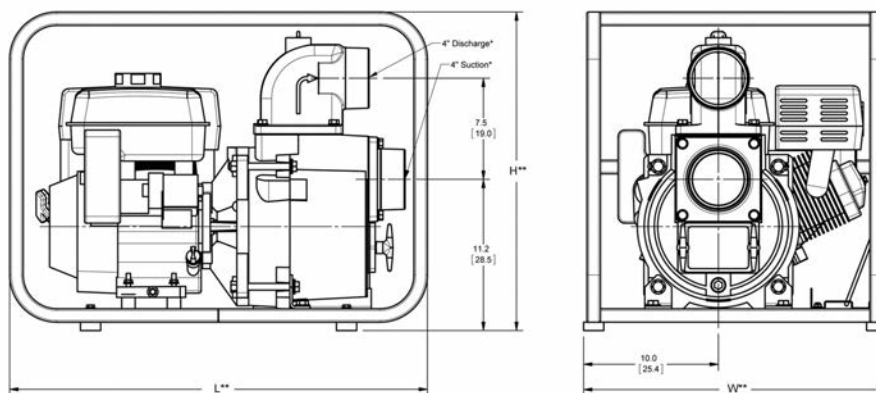

Model	DIS*	SUC*	L**	W**	H
3S9X Series	3	3	31.0 [78.7]	22.5 [57.1]	23.6 [60.0]
4SXX Series	4	4	31.0 [78.7]	22.5 [57.1]	23.6 [60.0]

Model	A
Gas/Diesel 3S9X	7.8 [19.8]
Gas/Diesel 4SXX	11.2 [28.5]

(\*) Standard NPT (Male) Pipe Thread.

(\*\*) This dimension may vary due to engine manufacturer's specifications.

NOTE: Dimensions are in inches (centimeters) and have a tolerance of ± 1/8".

## Standard Features

- Cast Iron Impeller
- Silicon Carbide Mechanical Seal with Graphite Impregnated Seat and Viton® Elastomers
- Heavy Duty Steel Roll Frame and Strainer Included
- Built-in Check Valve
- Removable/Replaceable Cast Iron Suction/Discharge Ports
- Discharge Port Rotates in 90° Increments
- Choice of Honda, Briggs and Stratton Vanguard Gasoline or Hatz Diesel Engines
- Vibration Dampening Feet
- Maximum Temperature 180° F
- EPDM/EPR O-rings Standard with Optional Viton®
- Optional Viton® O-ring/Check Valve Available
- Optional Wheel Kit Available
- QSP - Quick Ship Pumps